

Pressurisation Unit – Fluid Category 3 (45 kW max)

“Autofill” Model – AFCA - Datasheet Page 1 of 2

Description

Autofill AFCA is a new type of pressurisation unit for filling heating systems **less than 45 kW in a non-house or unlimited output in purely domestic premises.**

(For non-house applications with systems above 45 kW systems see datasheet Autofill models [AFS & AFP](#)). Autofill replaces traditional pressurisation units and requires no tank or pump. Autofill is exceptionally compact at just 300 mm square. The unit complies with the new Water Regulations for both filling and pressurising the primary system. The primary components consist of –

- Fluid Category 3 backflow prevention device
- Internal mechanical quick fill valve
- Top-up pressure controlling equipment
- High & low cut-out switches with BMS output
- Inlet and outlet (system) pressure gauges

The unit is supplied fully assembled and tested. Inlet and outlet stainless steel braided hoses with servicing valves and push fit connections are provided to facilitate installation.

Dual Filling Rates

The unit has two filling modes – quick fill and top-up. The quick fill allows for fast manual filling using the internal quick fill valve – more than 20 times faster than top-up filling. No filling loop is required. The internal quick fill valve enables rapid filling with fluid category 3 protection. No electricity is required, which is a significant benefit in plant rooms under construction. The unit incorporates a Pressure Regulating Valve, which guards against overpressure during the quick fill stage.

The normal topping-up is controlled by a small direct-acting solenoid valve. This method is accurate and reliable. Furthermore the low top-up rate avoids pressure surges, which could otherwise trigger the cut-out devices. Also the unit will not feed a major leak at high flow rates.

Filling Mode	Delta P bar	15 mm Lt/hr
Quick fill (quick fill valve open)	1.0	1200
Quick fill (quick fill valve open)	2.0	1650
Top-up (quick fill valve closed)	1.0	50
Top-up (quick fill valve closed)	2.0	70
Suggested Boiler Size		0 - 45 kW

For boiler systems larger than 45 kW use Autofill model AFS

Two neon warning lamps are fitted to the door to illustrate filling or standby. Additional neon's are available to indicate high or low cut out with volt free common fault output.

Supply Pressure

Autofill utilises the supply pressure for pressurising the system. Often the supply will be mains pressure. The pressure drop across the Autofill is 0.6 bar (6 m). Therefore the mains pressure can reliably be used for single storey buildings *(although normally sufficient mains pressure for ground and 1st and possibly 2nd floors).* For taller buildings, Autofill should be supplied from the domestic boosted cold water supply if available. Autofill's integral backflow protection means the supply can be the drinking (wholesome) water service. *Note – where the unit is installed in roof top plant room – the standard filling pressure is sufficient since the system is below.*



Model AFCA – Fluid Category 3
15 mm
supplied with flexible hoses
incorporating servicing valves

Water Regulations

The water companies in England and Wales accept heating systems with a heating output no more than 45 kW to be Fluid Category 3. Similarly, any size output in purely domestic premises is considered to be Fluid Category 3. *For non-house systems greater than 45 kW refer to datasheet Autofill – model AFS, which has Fluid Category 4 protection.* Unlike filling loops with an ED device, CA devices may be permanently connected.

Autofill AFCA does not require annual testing.

A correctly sized - contact us - and pre-charged expansion vessel is required (G17.1) - normally supplied with an Autofill – See [datasheet model EVCP](#)

Applications

Filling and topping up –

- Primary Heating Systems
- Under Floor Heating
- Refrigerating Equipment
- Chilled Water Circuits
- Cooling Circuits
- Industrial Processes



Expansion Vessel
model - EVCP

Arrow Valves Ltd

Tel: 01442 823123

Fax: 01442 823234

www.arrowvalves.co.uk

Arrow Valves Ltd reserve the right to change specifications, design and materials at any time without notice.
All unit-less dimensions in mm.

© Copyright Arrow Valves Ltd 2001-2013



Pressurisation Unit – Fluid Category 3 (45 kW max)

“Autofill” Model – AFCA - Datasheet Page 2 of 2

Cont.

Specification - mechanical

Connections	½” male BSP (for hoses)
Connection hoses (supplied)	15 mm stainless braided 300 mm metal push fit with serv. valve
Pressure Supply	10 bar max.
Pressure Outlet Max.	0.6 bar below supply to Autofill
Enclosure	IP55 with lockable door
Mounting Height	0.3–1.5 m
Water Regulations Approval (complete)	A020027

Specification – Electrical

Pressure Switches	Adjustable 0.2–6.0 bar
Factory Settings – Cold Fill	On 1.2 bar (falling) Off 1.5 bar (rising)
Low cut-out	0.5 bar (falling)
High cut-out	2.8 bar (rising)
Max. Current	3 A @ 230 V ac
Switch Enclosure	IP65
Cable Entries	Two M20 holes
Solenoid Supply	230 V 50 Hz IP65 via 5 A fused isolator (not supplied)

Materials

Cabinet	Steel (powder coated RAL 7032)
Fittings	Brass or stainless steel

Discharge

CA devices are permitted for Fluid Category 3 because the relief valve can open under fault conditions to prevent backflow. Normally there is no discharge from Autofill, even during operation. After filling a small discharge from the tundish can occur. The waste pipe can be reduced to 22 mm. The waste should be run to a gully in the plant room or externally with a warning pipe.

Dimensions

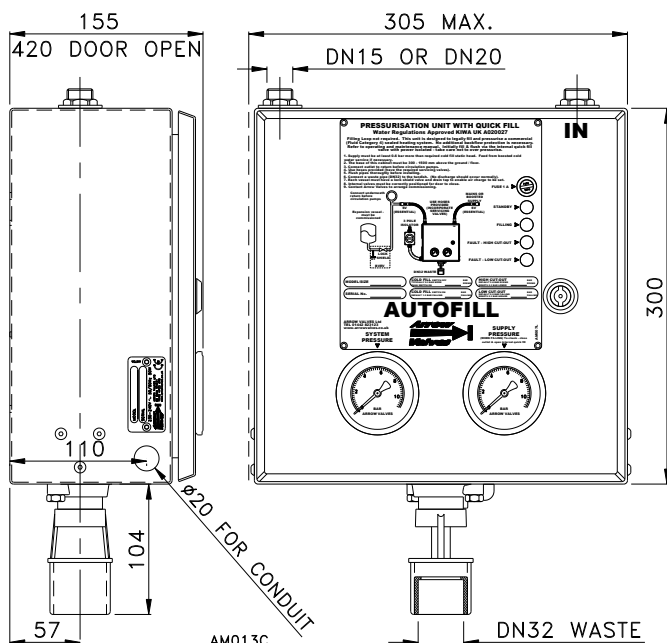

Wiring Diagram

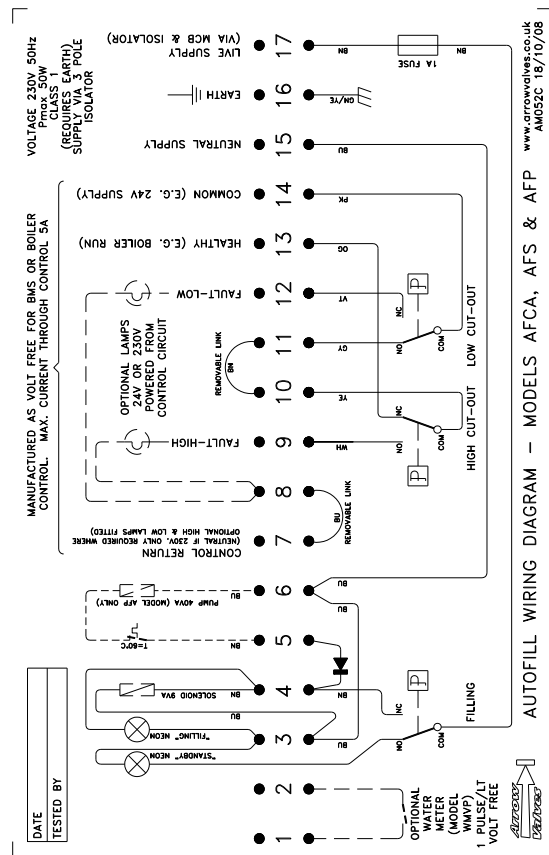

- Notes
- Two neons indicate standby and filling
 - Optional two additional neons indicate high or low faults

Ancillaries

The sealed heating system requires a correctly sized Expansion Vessel and controls.

- Available from Arrow Valves –
- Wall Mounting Bracket - AFBRA
 - Expansion Vessels - EVCP
 - Expansion Vessel Servicing Valve c/w Drain Tap – [BVEV](#)
 - Dosing Pots - [DP](#)
 - Dirt & Air Removers (de-aerators) – [ADR](#)
 - Water Meters - WMV3P15MPAF



A water meter should be fitted on the supply to Autofill (this will be cold). This indicates system volume, which enables the quantity of inhibitor to be added via a dosing pot. Also a meter indicates any system leakage, which again helps with re-dosing after repair. Model WMV is a volumetric meter (Class C) and therefore detects the smallest of flows. The digital mechanical display is easy to read to 0.1 litres. Volt free output 1 pulse/litre for BMS.

Codes and Descriptions

Size	Code	Description
15 mm	AFCA15	Autofill Pressurisation Unit FC3
15/22	AFBRA	Autofill Wall Mounting Bracket - Stainless
DN15	WMV3P15MPAF	AF Water Meter Class C 1 Pulse/Lt Cold MUBSP

Arrow Valves Ltd

Tel: 01442 823123 Fax: 01442 823234

www.arrowvalves.co.uk

Arrow Valves Ltd reserve the right to change specifications, design and materials at any time without notice.

All unit-less dimensions in mm.
© Copyright Arrow Valves Ltd 2001-2013

